

Chapter 2

Force Vector

2.1	<i>Definition of Force</i>	/ 23
2.2	<i>Properties of Force as a Vector Quantity</i>	/ 23
2.3	<i>Dimension and Units of Force</i>	/ 23
2.4	<i>Force Systems</i>	/ 24
2.5	<i>External and Internal Forces</i>	/ 24
2.6	<i>Normal and Tangential Forces</i>	/ 25
2.7	<i>Tensile and Compressive Force</i>	/ 25
2.8	<i>Coplanar Forces</i>	/ 25
2.9	<i>Collinear Forces</i>	/ 26
2.10	<i>Concurrent Forces</i>	/ 26
2.11	<i>Parallel Force</i>	/ 26
2.12	<i>Gravitational Force or Weight</i>	/ 26
2.13	<i>Distributed Force Systems and Pressure</i>	/ 27
2.14	<i>Frictional Forces</i>	/ 29
2.15	<i>Exercise Problems</i>	/ 31

2.1 Definition of Force

Force may be defined as mechanical disturbance or load. When you pull or push an object, you apply a force to it. You also exert a force when you throw or kick a ball. In all of these cases, the force is associated with the result of muscular activity. Forces acting on an object can deform, change its state of motion, or both. Although forces cause motion, it does not necessarily follow that force is always associated with motion. For example, a person sitting on a chair applies his/her weight on the chair, and yet the chair remains stationary. There are relatively few basic laws that govern the relationship between force and motion. These laws will be discussed in detail in later chapters.

2.2 Properties of Force as a Vector Quantity

Forces are vector quantities and the principles of vector algebra (see Appendix B) must be applied to analyze problems involving forces. To describe a force fully, its magnitude and direction must be specified. As illustrated in Fig. 2.1, a force vector can be illustrated graphically with an arrow such that the orientation of the arrow indicates the line of action of the force vector, the arrowhead identifies the direction and sense along which the force is acting, and the base of the arrow represents the point of application of the force vector. If there is a need for showing more than one force vector in a single drawing, then the length of each arrow must be proportional to the magnitude of the force vector it is representing.

Like other vector quantities, forces may be added by utilizing graphical and trigonometric methods. For example, consider the partial knee illustrated in Fig. 2.2. Forces applied by the quadriceps \underline{F}_Q and patellar tendon \underline{F}_P on the patella are shown. The resultant force \underline{F}_R on the patella due to the forces applied by the quadriceps and patellar tendon can be determined by considering the vector sum of these forces:

$$\underline{F}_R = \underline{F}_Q + \underline{F}_P \quad (2.1)$$

If the magnitude of the resultant force needs to be calculated, then the Pythagorean theorem can be utilized:

$$F_R = \sqrt{F_Q^2 + F_P^2} \quad (2.2)$$

2.3 Dimension and Units of Force

By definition, force is equal to mass times acceleration, acceleration is the time rate of change of velocity, and velocity is the time rate of change of relative position. The change in position

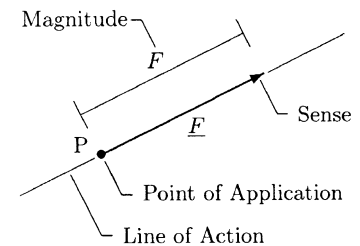

Fig. 2.1 Graphical representation of the force vector

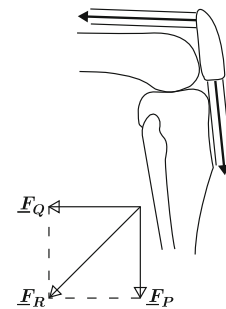

Fig. 2.2 Resultant force

is measured in terms of length units. Therefore, velocity has a dimension of length divided by time, acceleration has a dimension of velocity divided by time, and force has a dimension of mass times acceleration:

$$[\text{VELOCITY}] = \frac{[\text{POSITION}]}{[\text{TIME}]} = \frac{L}{T}$$

$$[\text{ACCELERATION}] = \frac{[\text{VELOCITY}]}{[\text{TIME}]} = \frac{L/T}{T} = \frac{L}{T^2}$$

$$[\text{FORCE}] = [\text{MASS}][\text{ACCELERATION}] = \frac{ML}{T^2}$$

Units of force in different unit systems are provided in Table 2.1.

Table 2.1 Units of force ($1 \text{ N} = 10^5 \text{ dyn}$, $1 \text{ N} = 0.225 \text{ lb}$)

SYSTEM	UNITS OF FORCE	SPECIAL NAME
SI	Kilogram-meter/second ²	Newton (N)
c-g-s	Gram-centimeter/second ²	Dyne (dyn)
British	Slug-foot/second ²	Pound (lb)

2.4 Force Systems

Any two or more forces acting on a single body form a *force system*. Forces constituting a force system may be classified in various ways. Forces may be classified according to their effect on the bodies upon which they are applied or according to their orientation as compared to one another.

2.5 External and Internal Forces

A force may be broadly classified as *external* or *internal*. Almost all commonly known forces are external forces. For example, when you push a cart, hammer a nail, sit on a chair, kick a football, or shoot a basketball, you apply an external force on the cart, nail, chair, football, or basketball. Internal forces, on the other hand, are the ones that hold a body together when the body is under the effect of externally applied forces. For example, a piece of string does not necessarily break when it is pulled from both ends. When a rubber band is stretched, the band elongates to a certain extent. What holds any material together under externally applied forces is the internal forces generated within that material. If we consider the human body as a whole,

then the forces generated by muscle contractions are also internal forces. The significance and details of internal forces will be studied by introducing the concept of “stress” in later chapters.

2.6 Normal and Tangential Forces

In mechanics, the word “normal” implies perpendicular. If a force acting on a surface is applied in a direction perpendicular to that surface, then the force is called a *normal force*. For example, a book resting on a flat horizontal desk applies a normal force on the desk, the magnitude of which is equal to the weight of the book (Fig. 2.3).

A *tangential force* is that applied on a surface in the direction parallel to the surface. A good example of tangential forces is the frictional force. As illustrated in Fig. 2.4, pushing or pulling a block will cause a frictional force to occur between the bottom surface of the block and the floor. The line of action of the frictional force is always tangential to the surfaces in contact.

2.7 Tensile and Compressive Force

A *tensile force* applied on a body will tend to stretch or elongate the body, whereas a *compressive force* will tend to shrink the body in the direction of the applied force (Fig. 2.5). For example, a tensile force applied on a rubber band will stretch the band. Poking into an inflated balloon will produce a compressive force on the balloon. It must be noted that there are certain materials upon which only tensile forces can be applied. For example, a rope, a cable, or a string cannot withstand compressive forces. The shapes of these materials will be completely distorted under compressive forces. Similarly, muscles contract to produce tensile forces that pull together the bones to which they are attached to. Muscles can neither produce compressive forces nor exert a push.

2.8 Coplanar Forces

A system of forces is said to be *coplanar* if all the forces are acting on a two-dimensional (plane) surface. Forces forming a coplanar system have at most two nonzero components. Therefore, with respect to the Cartesian (rectangular) coordinate frame, it is sufficient to analyze coplanar force systems by considering the x and y components of the forces involved.

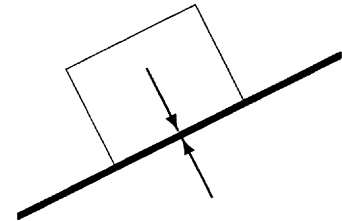

Fig. 2.3 Forces normal to the surfaces in contact

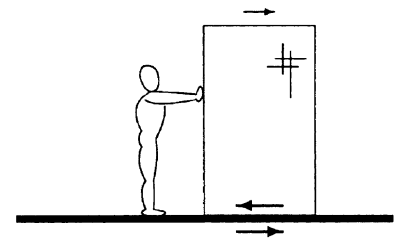

Fig. 2.4 Frictional forces are tangential forces

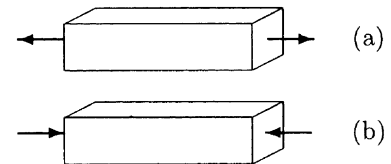

Fig. 2.5 (a) Tensile and (b) compressive forces

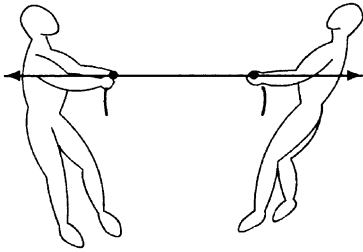

Fig. 2.6 Collinear forces

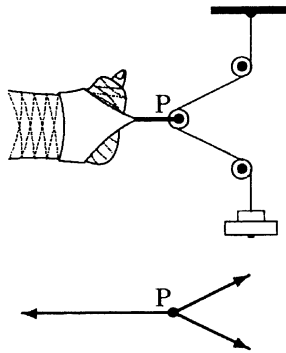

Fig. 2.7 Concurrent forces

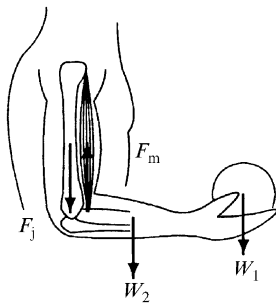

Fig. 2.8 Parallel forces

2.9 Collinear Forces

A system of forces is *collinear* if all the forces have a common line of action. For example, the forces applied on a rope in a rope-pulling contest form a collinear force system (Fig. 2.6).

2.10 Concurrent Forces

A system of forces is *concurrent* if the lines of action of the forces have a common point of intersection. Examples of concurrent force systems can be seen in various traction devices, as illustrated in Fig. 2.7. Due to the weight in the weight pan, the cables stretch and forces are applied on the pulleys and the leg. The force applied on the leg holds the leg in place.

2.11 Parallel Force

A set of forces form a *parallel* force system if the lines of action of the forces are parallel to each other. An example of parallel force systems is illustrated in Fig. 2.8 by a human arm flexed at a right angle and holding an object. The forces acting on the forearm are the weight of the object W_1 , the weight of the arm itself W_2 , the tension in the biceps muscle F_M , and the joint reaction force at the elbow F_j . These forces are parallel to each other, thus forming a system of parallel forces.

2.12 Gravitational Force or Weight

The force exerted by Earth on an object is called the *gravitational force* or *weight* of the object. The magnitude of weight of an object is equal to the mass of the object times the magnitude of gravitational acceleration, $w = m \cdot g$, where w is the weight of the object, m is the mass of the object, and g is the gravitational acceleration. The magnitude of gravitational acceleration for different unit systems is listed in Table 2.2. These values are valid only on the surface of Earth. The magnitude of the gravitational acceleration can vary slightly with altitude.

Table 2.2 Gravitational acceleration on Earth

SYSTEM	GRAVITATIONAL ACCELERATION
SI	9.81 m/s ²
c-g-s	981 cm/s ²
British	32.2 ft/s ²

For our applications, we shall assume g to be a constant.

The terms mass and weight are often confused with one another. Mass is a property of a body. Weight is the force of gravity acting on the mass of the body. A body has the same mass on Earth and on the moon. However, the weight of a body is about six times as much on Earth as on the moon, because the magnitude of the gravitational acceleration on the moon is about one-sixth of what it is on Earth. Therefore, a 10 kg mass on Earth weighs about 98 N on Earth, while it weighs about 17 N on the moon.

Like force, acceleration is a vector quantity. The direction of gravitational acceleration and gravitational force vectors is always toward the center of Earth, or always vertically downward. The force of gravity acts on an object at all times. If we drop an object from a height, it is the force of gravity that will pull the object downward.

When an object is at rest on the ground, the gravitational force does not disappear. An object at rest or in static equilibrium simply means that the net force acting on the object is zero (Fig. 2.9).

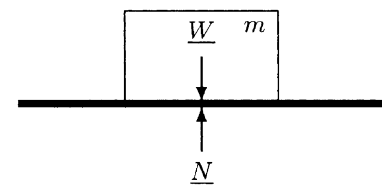

Fig. 2.9 The net force on an object at rest is zero (correction)

2.13 Distributed Force Systems and Pressure

Consider a pile of sand lying on a flat horizontal surface, as illustrated in Fig. 2.10a. The sand exerts force or load on the surface, which is distributed over the area under the sand. The load is not uniformly distributed over this area. The marginal regions under the pile are loaded less as compared to the central regions (Fig. 2.10b). For practical purposes, the distributed load applied by the sand may be represented by a single force, called the *equivalent force* or *concentrated load*. The magnitude of the equivalent force would be equal to the total weight of the sand (Fig. 2.10c). The line of action of this force would pass through a point, called the *center of gravity*. For some applications, we can assume that the entire weight of the pile is concentrated at the center of gravity of the load. For uniformly distributed loads, such as the load applied by the rectangular block on the horizontal surface shown in Fig. 2.11, the center of gravity coincides with the geometric center of the load. For non-uniformly distributed loads, the center of gravity can be determined by experimentation (see Chap. 4).

Center of gravity is associated with the gravitational force of Earth. There is another concept called *center of mass*, which is independent of gravitational effects. For a large object or a structure, such as the Empire State building in New York City, the center of gravity may be different than the center of mass because the magnitude of gravitational acceleration varies with

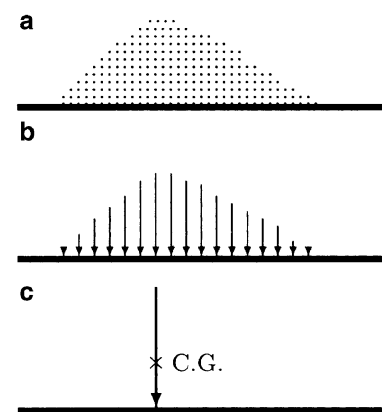

Fig. 2.10 A pile of sand (a), distributed load on the ground (b), and an equivalent force (c)

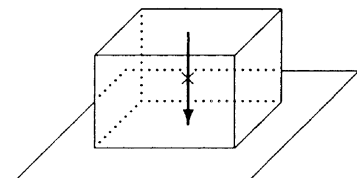

Fig. 2.11 Rectangular block

altitude. For relatively small objects and for our applications, the difference between the two can be ignored.

Another important concept associated with distributed force systems is *pressure*, which is a measure of the intensity of distributed loads. By definition, *average pressure* is equal to total applied force divided by the area of the surface over which the force is applied in a direction perpendicular to the surface. It is also known as *load intensity*. For example, if the bottom surface area of the rectangular block in Fig. 2.11 is A and the total weight of the block is W , then the magnitude p of the pressure exerted by the block on the horizontal surface can be calculated by:

$$p = \frac{W}{A} \tag{2.3}$$

It follows that the dimension of pressure has the dimension of force (ML/T^2) by the dimension of area (L^2):

$$[\text{PRESSURE}] = \frac{[\text{FORCE}]}{[\text{AREA}]} = \frac{M \cdot L/T^2}{L^2} = \frac{M}{LT^2}$$

Units of pressure in different unit systems are listed in Table 2.3.

Table 2.3 *Units of pressure*

SYSTEM	UNITS OF PRESSURE	SPECIAL NAME
SI	kg/ms ² or N/m ²	Pascal (Pa)
c-g-s	g/cm s ² or dyn/cm ²	
British	lb/ft ² or lb/in. ²	psf or psi

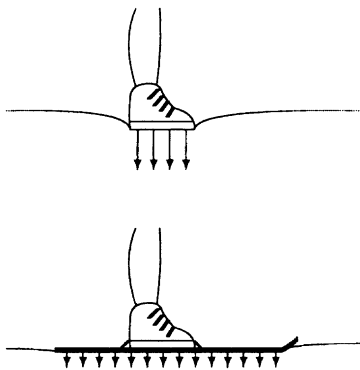

Fig. 2.12 *Intensity of force (pressure) applied on the snow by a pair of boots is higher than that applied by a pair of skis*

The principles behind the concept of pressure have many applications. Note that the larger the area over which a force is applied, the lower the magnitude of pressure. If we observe two people standing on soft snow, one wearing a pair of boots and the other wearing skis, we can easily notice that the person wearing boots stands deeper in the snow than the skier. This is simply because the weight of the person wearing boots is distributed over a smaller area on the snow, and therefore applies a larger force per unit area of snow (Fig. 2.12). It is obvious that the sensation and pain induced by a sharp object is much more severe than that produced by a force that is applied by a dull object.

A prosthesis that fits the amputated limb, or a set of dentures that fits the gum and the bony structure properly, would feel and function better than an improperly fitted implant or replacement device. The idea is to distribute the forces involved as uniformly as possible over a large area.

2.14 Frictional Forces

Frictional forces occur between two surfaces in contact when one surface slides or tends to slide over the other. When a body is in motion on a rough surface or when an object moves in a fluid (a viscous medium such as water), there is resistance to motion because of the interaction of the body with its surroundings. In some applications friction may be desirable, while in others it may have to be reduced to a minimum. For example, it would be impossible to start walking in the absence of frictional forces. Automobile, bicycle, and wheelchair brakes utilize the principles of friction. On the other hand, friction can cause heat to be generated between the surfaces in contact. Excess heat can cause early, unexpected failure of machine parts. Friction may also cause wear.

There are several factors that influence frictional forces. Friction depends on the nature of the two sliding surfaces. For example, if all other conditions are the same, the friction between two metal surfaces would be different than the friction between two wood surfaces in contact. Friction is larger for materials that strongly interact. Friction depends on the surface quality and surface finish. A good surface finish can reduce frictional effects. The frictional force does not depend on the total surface area of contact.

Consider the block resting on the floor, as shown in Fig. 2.13. The block is applying its weight \underline{W} on the floor. In return the floor is applying a normal force \underline{N} on the block, such that the magnitudes of the two forces are equal ($N = W$). Now consider that a horizontal force \underline{F} is applied on the block to move it toward the right. This will cause a frictional force \underline{f} to develop between the block and the floor. As long as the block remains stationary (in static equilibrium), the magnitude f of the frictional force would be equal to the magnitude F of the applied force. This frictional force is called the *static friction*.

If the magnitude of the applied force is increased, the block will eventually slip or begin sliding over the floor. When the block is on the verge of sliding (the instant just before sliding occurs), the magnitude of the static friction is maximum (f_{\max}). When the magnitude of the applied force exceeds f_{\max} , the block moves toward the right. When the block is in motion, the resistance to motion at the surfaces of contact is called the *kinetic* or *dynamic friction*, \underline{f}_k . In general, the magnitude of the force of kinetic friction is lower than the maximum static friction ($f_k < f_{\max}$) and the magnitude of the applied force ($f_k < F$). The difference between the magnitudes of the applied force and kinetic friction causes the block to accelerate toward the right.

It has been experimentally determined that the magnitudes of both static and kinetic friction are directly proportional to the

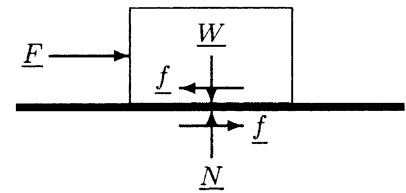

Fig. 2.13 Friction occurs on surfaces when one surface slides or tends to slide over the other

normal force (N in Fig. 2.13) acting on the surfaces in contact. The constant of proportionality is commonly referred to with μ (mu) and is called the *coefficient of friction*, which depends on such factors as the material properties, the quality of the surface finish, and the conditions of the surfaces in contact. The coefficient of friction also varies depending on whether the bodies in contact are stationary or sliding over each other. To be able to distinguish the frictional forces involved at static and dynamic conditions, two different friction coefficients are defined. The *coefficient of static friction* (μ_s) is associated with static friction, and the *coefficient of kinetic friction* (μ_k) is associated with kinetic or dynamic friction. The magnitude of the static frictional force is such that $f_s = \mu_s N = f_{max}$ when the block is on the verge of sliding, and $f_s < \mu_s N$ when the magnitude of the applied force is less than the maximum frictional force, in which case the magnitude of the force of static friction is equal in magnitude to the applied force ($f_s = F$). The formula relating the kinetic friction and the normal force is:

$$F_k = \mu_k N \tag{2.4}$$

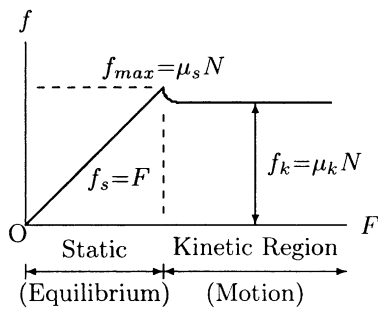

Fig. 2.14 The variation of frictional force as a function of applied force

The variations of frictional force with respect to the force applied in a direction parallel (tangential) to the surfaces in contact are shown in Fig. 2.14. For any given pair of materials, the coefficient of kinetic friction is usually lower than the coefficient of static friction. The coefficient of kinetic friction is approximately constant at moderate sliding speeds. At higher speeds, μ_k may decrease because of the heat generated by friction. Sample coefficients of friction are listed in Table 2.4. Note that the figures provided in Table 2.4 are some average ranges and do not distinguish between static and kinetic friction coefficients.

Table 2.4 Coefficients of friction

SURFACES IN CONTACT	FRICTION COEFFICIENT
Wood on wood	0.25–0.50
Metal on metal	0.30–0.80
Plastic on plastic	0.10–0.30
Metal on plastic	0.10–0.20
Rubber on concrete	0.60–0.70
Rubber on tile	0.20–0.40
Rubber on wood	0.70–0.75
Bone on metal	0.10–0.20
Cartilage on cartilage	0.001–0.002

Frictional forces always act in a direction tangent to the surfaces in contact. If one of the two bodies in contact is moving, then the frictional force acting on that body has a direction opposite to the direction of motion. For example, under the action of applied force, the block in Fig. 2.13 tends to move toward the right. The direction of the frictional force on the block is toward the left, trying to stop the motion of the block. The frictional forces always occur in pairs because there are always two surfaces in contact for friction to occur. Therefore, in Fig. 2.13, a frictional force is also acting on the floor. The magnitude of the frictional force on the floor is equal to that of the frictional force acting on the block. However, the direction of the frictional force on the floor is toward the right.

The effects of friction and wear may be reduced by introducing additional materials between the sliding surfaces. These materials may be solids or fluids, and are called *lubricants*. Lubricants placed between the moving parts reduce frictional effects and wear by reducing direct contact between the moving parts. In the case of the human body, the diarthrodial joints (such as the elbow, hip, and knee joints) are lubricated by the *synovial fluid*. The synovial fluid is a viscous material that reduces frictional effects, reduces wear and tear of articulating surfaces by limiting direct contact between them, and nourishes the articular cartilage lining the joint surfaces.

Although diarthrodial joints are subjected to very large loading conditions, the cartilage surfaces undergo little wear under normal, daily conditions. It is important to note that introducing a fluid as a lubricant between two solid surfaces undergoing relative motion changes the discussion of how to assess the frictional effects. For example, frictional force with a viscous medium present is not only a function of the normal forces (pressure) involved, but also depends on the relative velocity of the moving parts. A number of lubrication modes have been defined to account for frictional effects at diarthrodial joints under different loading and motion conditions. These modes include hydrodynamic, boundary, elastohydrodynamic, squeeze-film, weeping, and boosted lubrication.

2.15 Exercise Problems

Problem 2.1 As illustrated in Fig. 2.15, consider two workers who are trying to move a block. Assume that both workers are applying equal magnitude forces of 200 N. One of the workers is pushing the block toward the north and the other worker is

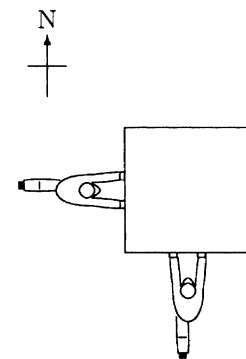

Fig. 2.15 Problem 2.1

pushing it toward the east. Determine the magnitude and direction of the net force applied by the workers on the block.

Answer: 283 N, northeast

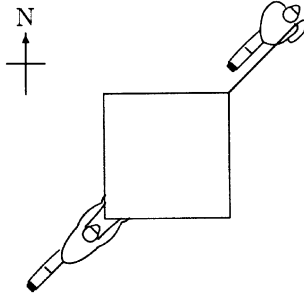

Fig. 2.16 Problem 2.2

Problem 2.2 As illustrated in Fig. 2.16, consider two workers who are trying to move a block. Assume that both workers are applying equal magnitude forces of 200 N. One of the workers is pushing the block toward the northeast, while the other is pulling it in the same direction. Determine the magnitude and direction of the net force applied by the workers on the block.

Answer: 400 N, northeast

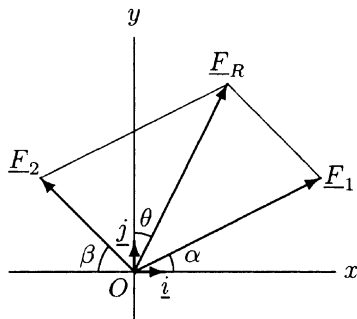

Fig. 2.17 Problem 2.3

Problem 2.3 Consider the two forces, \underline{F}_1 and \underline{F}_2 , shown in Fig. 2.17. Assume that these forces are applied on an object in the xy -plane. The first force has a magnitude $F_1 = 15$ N and is applied in a direction that makes an angle $\alpha = 30^\circ$ with the positive x axis, and the second force has a magnitude $F_2 = 10$ N and is applied in a direction that makes an angle $\beta = 45^\circ$ with the negative x axis.

- Calculate the scalar components of \underline{F}_1 and \underline{F}_2 along the x and y directions.
- Express \underline{F}_1 and \underline{F}_2 in terms of their components.
- Determine an expression for the resultant force vector, \underline{F}_R .
- Calculate the magnitude of the resultant force vector.
- Calculate angle θ that \underline{F}_R makes with the positive y axis.

Answers:

- $F_{1x} = 13.0$ N, $F_{1y} = 7.5$ N, $F_{2x} = 7.1$ N, $F_{2y} = 7.1$ N
- $\underline{F}_1 = 13.0\mathbf{i} + 7.5\mathbf{j}$ and $\underline{F}_2 = -7.1\mathbf{i} + 7.1\mathbf{j}$
- $\underline{F}_R = 5.9\mathbf{i} + 14.6\mathbf{j}$
- $F_R = 15.7$ N
- $\theta = 22^\circ$

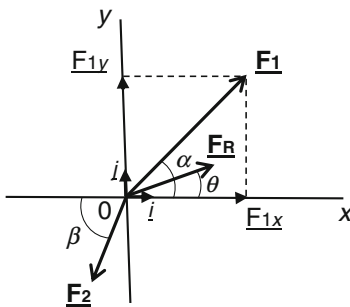

Fig. 2.18 Problem 2.4

Problem 2.4 Consider forces shown in Fig. 2.18. \underline{F}_R is the resultant force vector making an angle $\theta = 27^\circ$ with the positive x axis. The magnitude of the resultant force is $F_R = 21.4$ N. Furthermore, $F_{1x} = 26$ N and $F_{1y} = 25$ N represent the scalar components of the force \underline{F}_1 .

- (a) Calculate the magnitude of the force \underline{F}_1 .
 (b) Calculate an angle α that the force \underline{F}_1 makes with the positive x axis.
 (c) Calculate the magnitude of the force \underline{F}_2 .
 (d) Calculate an angle β that the force \underline{F}_2 makes with the horizontal.

Answers: (a) $F_1 = 36.1$ N; (b) $\alpha = 43.9^\circ$; (c) $F_2 = 16.8$ N;
 (d) $\beta = 65.7^\circ$

Problem 2.5 Consider four forces \underline{F}_1 , \underline{F}_2 , \underline{F}_3 , and \underline{F}_4 shown in Fig. 2.19. Assume that these forces are applied on an object in the xy -plane. The first, second, and third forces have a magnitude of $F_1 = 32$ N, $F_2 = 45$ N, and $F_3 = 50$ N, respectively, and they make angles $\alpha = 35^\circ$, $\beta = 32^\circ$, and $\gamma = 50^\circ$ with the positive x axis. The force \underline{F}_4 has a magnitude $F_4 = 55$ N and its line of action makes an angle $\theta = 65^\circ$ with the negative x axis.

- (a) Calculate the scalar components of the resultant force vector \underline{F}_R .
 (b) Calculate the magnitude F_R of the resultant force.
 (c) Calculate an angle τ that the resultant force vector \underline{F}_R makes with the horizontal.

Answers: (a) $F_{Rx} = 73.3$ N, $F_{Ry} = 93.5$ N; (b) $F_R = 118.8$ N;
 (c) $\tau = 51.9^\circ$

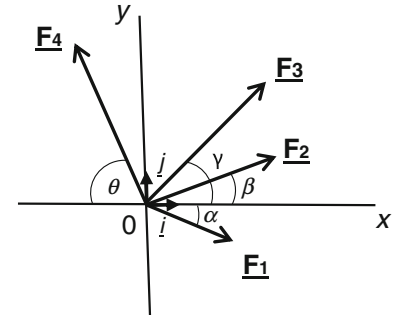

Fig. 2.19 Problem 2.5

Problem 2.6 As illustrated in Fig. 2.20, consider a 2 kg, 20 cm \times 30 cm book resting on a table. Calculate the average pressure applied by the book on the table top.

Answer: 327 Pa



Fig. 2.20 Problem 2.6

Problem 2.7 As shown in Fig. 2.21, consider a 50 kg cylindrical barrel resting on a wooden pallet. The pressure applied on the pallet by the barrel is 260 Pa. What is the radius r of the barrel?

Answer: $r = 0.77$ m

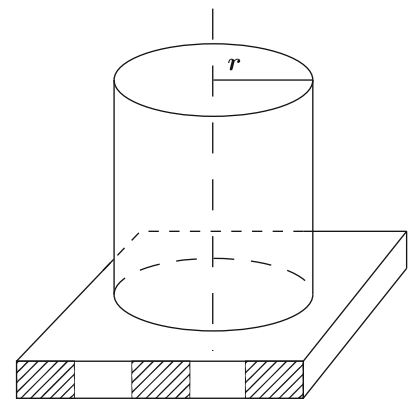

Fig. 2.21 Problem 2.7

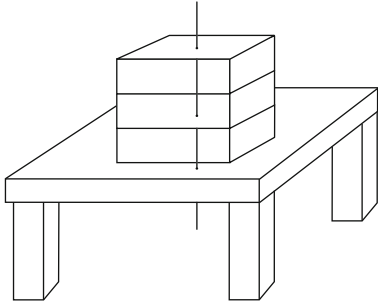

Fig. 2.22 Problem 2.8

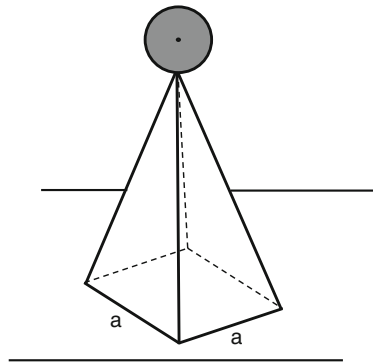

Fig. 2.23 Problem 2.9

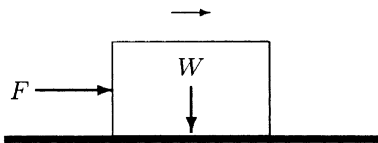

Fig. 2.24 Problems 2.10, 2.11, 2.12

Problem 2.8 As illustrated in Fig. 2.22, a stack of three identical boxes of 10 kg each are placed on top of the table. The bottom area of the box is 40 cm \times 50 cm. Calculate the average pressure applied by the boxes on the table.

Answer: $P = 1470 \text{ Pa}$

Problem 2.9 As illustrated in Fig. 2.23, consider an architectural structure that includes a 35 kg sphere mounted on top of a square-based pyramid. The weight of the pyramid is $W = 650 \text{ N}$ and the side of its base is $a = 0.7 \text{ m}$. Calculate the average pressure applied by the structure on the floor.

Answer: $P = 2026.5 \text{ Pa}$

Problem 2.10 As illustrated in Fig. 2.24, consider a block that weighs 400 N and is resting on a horizontal surface. Assume that the coefficient of static friction between the block and the horizontal surface is 0.3. What is the minimum horizontal force required to move the block toward the right?

Answer: Slightly greater than 120 N

Problem 2.11 As shown in Fig. 2.24, consider a block moving over the floor to the right as the result of externally applied force $F = 280 \text{ N}$. Assume that the coefficient of kinetic friction between the block and the floor is 0.35. What is the mass (m) of the block?

Answer: $m = 81.6 \text{ kg}$

Problem 2.12 As shown in Fig. 2.24, consider a block moving over the floor to the right as the result of horizontal force $F = 62.5 \text{ N}$ applied on the block. The coefficient of friction between the block and the floor is 0.25. What is the weight of the block?

Answer: $W = 250 \text{ N}$

Problem 2.13 As illustrated in Fig. 2.25, consider a person pushing a 50 kg file cabinet over a tile-covered floor by applying 74 N horizontal force. What is the coefficient of friction between the file cabinet and the floor?

Answer: $\mu = 0.15$

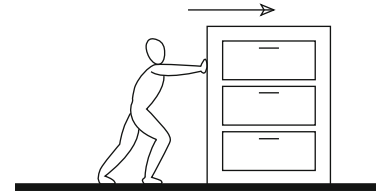

Fig. 2.25 Problems 2.13 and 2.14

Problem 2.14 As illustrated in Fig. 2.25, consider a person trying to push a file cabinet over a wooden floor. The file cabinet contains various folders, office supplies, and accessories on the shelves inside. The total weight of the loaded file cabinet is $W = 900$ N; however, according to its specifications, the weight of the empty file cabinet is $W_1 = 500$ N. Furthermore, the coefficient of static friction between the file cabinet and the floor is $\mu = 0.4$.

- What is the magnitude of horizontal force the person must apply to start moving the loaded file cabinet over the floor?
- What is the magnitude of horizontal force the person must apply to start moving the empty file cabinet over the floor?
- What is the change in force requirements of the task when pushing the loaded file cabinet over the floor?

Answers:

- Slightly greater than 360 N
- Slightly greater than 200 N
- 80% increase

Problem 2.15 As shown in Fig. 2.26, consider a block that weighs W . Due to the effect of gravity, the block is sliding down a slope that makes an angle θ with the horizontal. The coefficient of kinetic friction between the block and the slope is μ_k .

Show that the magnitude of the frictional force generated between the block and the slope is $f = \mu_k W \cos \theta$.

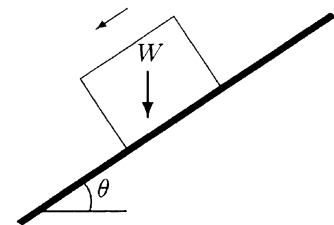

Fig. 2.26 Problem 2.15

Problem 2.16 As shown in Fig. 2.27, a person is trying to push a box weighing 500 N up an inclined surface by applying a force parallel to the incline. If the coefficient of friction between the box and the incline is 0.4, and the incline makes an angle

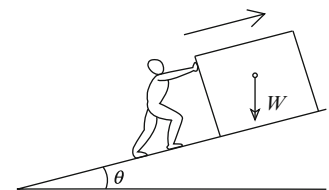

Fig. 2.27 Problem 2.16

$\theta = 25^\circ$ with the horizontal, determine the magnitude of the frictional force(s) acting on the box.

Answer: $f = 181.3\text{N}$

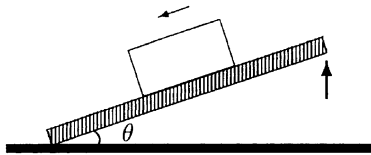

Fig. 2.28 *Problem 2.17*

Problem 2.17 Figure 2.28 shows a simple experimental method to determine the coefficient of static friction between surfaces in contact. This method is applied by placing a block on a horizontal plate, tilting the plate slowly until the block starts sliding over the plate, and recording the angle that the plate makes with the horizontal at the instant when the sliding occurs. This critical angle (θ_c) is called the *angle of repose*. At the instant just before the sliding occurs, the block is in static equilibrium.

Through force equilibrium, show that the coefficient of static friction just before motion starts is $\mu = \tan \theta_c$.



<http://www.springer.com/978-3-319-44737-7>

Fundamentals of Biomechanics

Equilibrium, Motion, and Deformation

Özkaya, N.; Leger, D.; Goldsheyder, D.; Nordin, M.

2017, XV, 454 p., Hardcover

ISBN: 978-3-319-44737-7